



## Avantajele dintr-o privire

<i>ULTRA</i> dynamic .....	24
<i>SILVER</i> dynamic .....	26
<i>BLUE</i> dynamic .....	28
<i>BLACK</i> dynamic .....	32

## Informații tehnice

Lista de referință .....	36
Tipuri de adaptor .....	37

<b>Lista de atribuire</b> .....	<b>71</b>
---------------------------------	-----------





## **ULTRA dynamic**

### **Cele mai bune performanțe pentru necesar extrem de energie**





Bateria *ULTRA* dinamică cu tehnologie AGM acoperă în orice situație de mers și cele mai ridicate nevoi de energie și garantează în același timp o putere sigură de pornire. Decisive în acest sens sunt debitul său enorm de energie și o stabilitate extremă a ciclurilor. Chiar și în cazul încărcării insuficiente în cazul călătoriilor scurte sau a consumului ridicat de energie în traficul urban, Stop-and-Go precum și în funcționarea pe loc, bateria nouă *ULTRA* dinamică asigură în orice caz o alimentare constantă a rețelei de bord. *ULTRA* dynamic este momentan cea mai puternic dezvoltată combinație între o baterie starter de înaltă capacitate și o alimentare mobilă cu energie, la același nivel constant ridicat.

- Tehnologia AGM – Nicio pierdere de material activ prin fixarea electrolitului.**
- Stabilitate extremă a ciclurilor – debit mai mare de energie**
- Mai multă putere de pornire la rece – electrozi mai înalți, deoarece nu este nevoie de o rezervă de electrolit.**
- Durată de viață mai mare – Uzare încetinită a bateriei datorită tehnologiei AGM.**
- Siguranță împotriva scurgerilor și a răsturnării – montare independentă de poziție și fără risc pentru mediu, chiar și în cazul unui accident.**
- Absolut fără necesități de întreținere – fără consum de apă, recombinație de oxigen, Poate fi depozitată timp de 15 luni.**

# ULTRA dynamic

Gama de tipuri

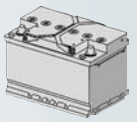
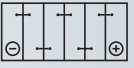
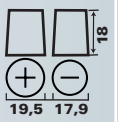
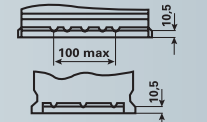
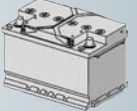
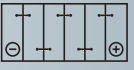
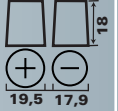
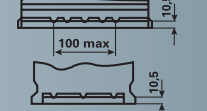

DOUBLE LIFETIME 570 901 076	NEW TECH E39	70Ah	760A					
570 901 076	E39	70	760	H6/L3 	0 	1  18 19,5 17,9	B13  100 max 10,5 10,5	a: 278 mm b: 175 mm c: 190 mm
595 901 085	G14	95	850	H8/L5 	0 	1  18 19,5 17,9	B13  100 max 10,5 10,5	a: 353 mm b: 175 mm c: 190 mm















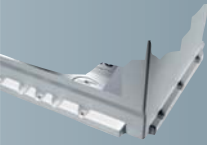

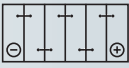
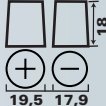
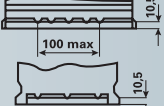
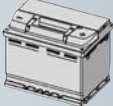
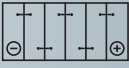
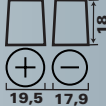
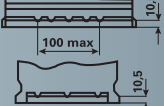

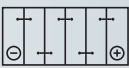
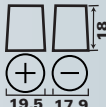
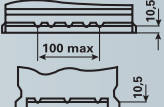
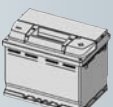

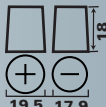
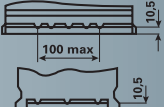

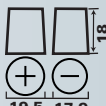
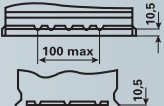
## ***SILVER dynamic***

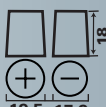
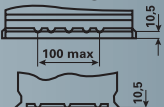
Putere maximă pentru cerințe maxime. Noua baterie VARTA *SILVER dynamic* cu cele peste 10 modele stabilește criterii noi pe piață și depășește momentan chiar și cerințele producătorilor de automobile internaționali. Alimentare fidelă chiar și atunci când există foarte mulți consumatori. Puterea de pornire la rece concentrată (520-920 A), chiar și în condiții climatice extreme și capacitate foarte ridicată (52-110 Ah), fac din acest pachet de forță un produs de vârf al trio-ului VARTA dynamic.

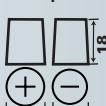
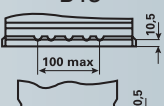
- Pentru vehicule cu necesar de putere foarte ridicat***
- Ideal în cazul consumatorilor electrici numeroși***
- Produs High End pe piață***
- Optim pentru motoare pe motorină***
- Durată de funcționare mai mare datorită aliajului de argint eficace VARTA***

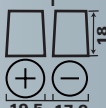
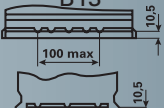
# Noua SILVER dynamic

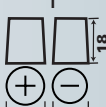
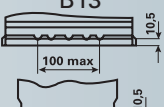
Gama de tipuri

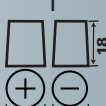
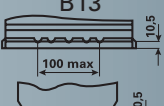
<b>552 401 052</b>	<b>C6</b> <small>VARTA code</small>	<b>52Ah</b>	<b>520</b> <small>Energy reserve (Ah)</small>					
552 401 052	C6	52	520	T4/LB1 	0 	1 	B13 	a: 207 mm b: 175 mm c: 175 mm
554 400 053	C30	54	530	H4/L1 	0 	1 	B13 	a: 207 mm b: 175 mm c: 190 mm
561 400 060	D21	61	600	T5/LB2 	0 	1 	B13 	a: 242 mm b: 175 mm c: 175 mm
563 400 061	D15	63	610	H5/L2 	0 	1 	B13 	a: 242 mm b: 175 mm c: 190 mm
563 401 061	D39	63	610	H5/L2 	1 	1 	B13 	a: 242 mm b: 175 mm c: 190 mm
574 402 075	E38	74	750	T6/LB3 	0 	1 	B13 	a: 278 mm b: 175 mm c: 175 mm
577 400 078	E44	77	780	H6/L3 	0 	1 	B13 	a: 278 mm b: 175 mm c: 190 mm
585 200 080	F18	85	800	T7/LB4 	0 	1 	B13 	a: 315 mm b: 175 mm c: 175 mm
600 402 083	H3	100	830	H8/L5 	0 	1 	B13 	a: 353 mm b: 175 mm c: 190 mm
610 402 092	I1	110	920	H9/L6 	0 	1 	B13 	a: 393 mm b: 175 mm c: 190 mm



## ***BLUE dynamic***













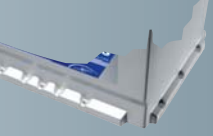

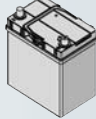

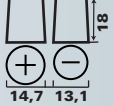

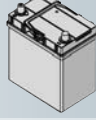

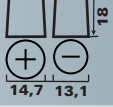
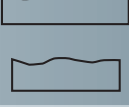
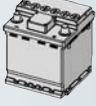

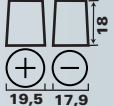
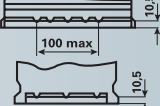
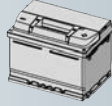

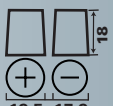
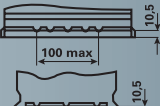
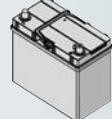
*BLUE dynamic* este cea mai vândută linie de baterii din magazinele de piese de schimb. Un motiv bun de a prezenta urmașa sa perfecționată. Valorile electrice ale puterii bateriei *BLUE dynamic* corespund sau depășesc cele ale echipamentului original. O capacitate de până la 95 Ah asigură un plus de siguranță și putere chiar și la echipamentele de vârf și fac din *BLUE dynamic* o baterie bună la toate cu acoperire mare pe piață. Acest lucru este valabil și pentru dimensionarea specifică bateriilor mașinilor asiatice.

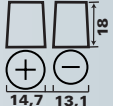

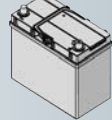

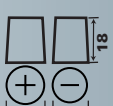

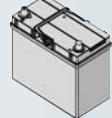
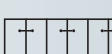
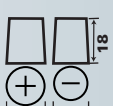





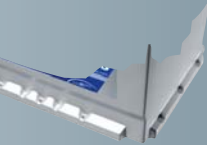

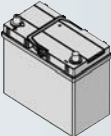
- Pentru autovehicule moderne din toate clasele***
- Putere experimentată, mereu îmbunătățită***
- Cel mai vândut produs de pe piață***
- Durată de funcționare mai mare datorită aliajului de argint eficace VARTA***

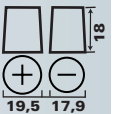
# Noua BLUE dynamic

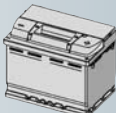
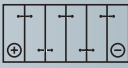
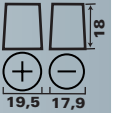
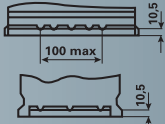
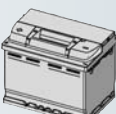
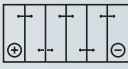
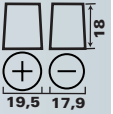
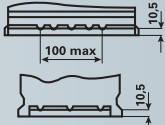
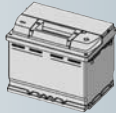
Gama de tipuri

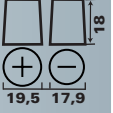
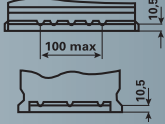
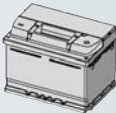
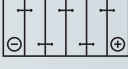
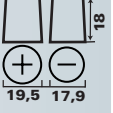
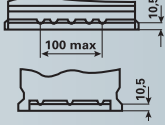
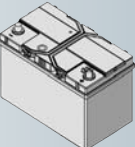
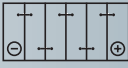
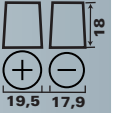

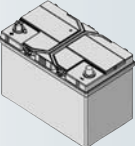
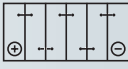
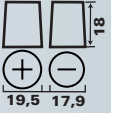
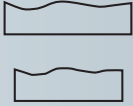
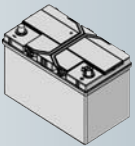

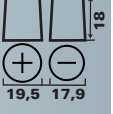
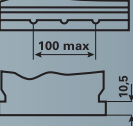









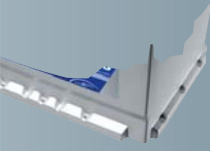

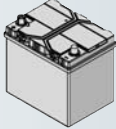
540 126 033	A14	40Ah	330					
540 126 033	A14	40	330	B19L 	0 	3 	B00 	a: 187 mm b: 127 mm c: 227 mm
540 127 033	A15	40	330	B19R 	1 	3 	B00 	a: 187 mm b: 127 mm c: 227 mm
542 400 039	B35	42	390	H3/L0 	0 	1 	B13 	a: 175 mm b: 175 mm c: 190 mm
544 402 044	B18	44	440	T4/LB1 	0 	1 	B13 	a: 207 mm b: 175 mm c: 175 mm
545 155 033	B31	45	330	B24L 	0 	3 	B00 	a: 238 mm b: 129 mm c: 227 mm
545 156 033	B32	45	330	B24LS 	0 	1 	B00 	a: 238 mm b: 129 mm c: 227 mm
545 157 033	B33	45	330	B24R 	1 	3 	B00 	a: 238 mm b: 129 mm c: 227 mm

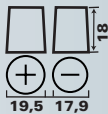
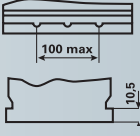
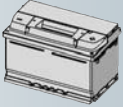
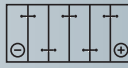
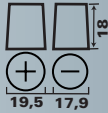
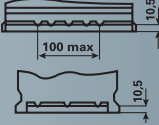
540 126 033	A14 VARTA.com	40Ah	330					
545 158 033	B34	45	330	B24RS 	1 	1 	B00 	a: 238 mm b: 129 mm c: 227 mm
552 400 047	C22	52	470	H4/L1 	0 	1 	B13 	a: 207 mm b: 175 mm c: 190 mm
560 127 054	D43	60	540	H5/L2 	1 	1 	B13 	a: 242 mm b: 175 mm c: 190 mm
560 408 054	D24	60	540	H5/L2 	0 	1 	B13 	a: 242 mm b: 175 mm c: 190 mm
560 409 054	D59	60	540	T5/LB2 	0 	1 	B13 	a: 242 mm b: 175 mm c: 175 mm
560 410 054	D47	60	540	D23L 	0 	1 	B00 	a: 232 mm b: 173 mm c: 225 mm
560 411 054	D48	60	540	D23R 	1 	1 	B00 	a: 232 mm b: 173 mm c: 225 mm
570 412 063	E23	70	630	D26L 	0 	1 	B01 	a: 261 mm b: 175 mm c: 220 mm

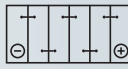
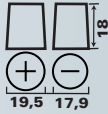
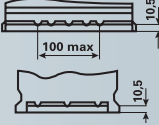

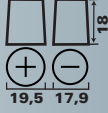
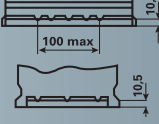
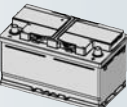
# Noua BLUE dynamic

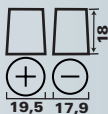
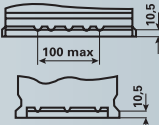
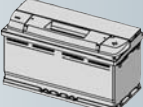
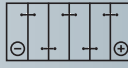
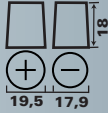
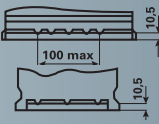
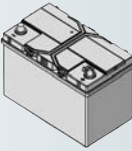
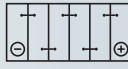
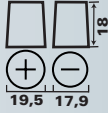
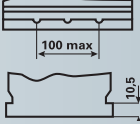
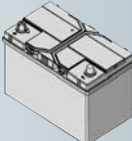
## Gama de tipuri

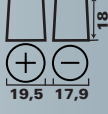
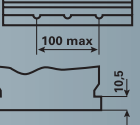
540 126 033	A14 VARTA.com	40Ah	330					
570 413 063	E24	70	630	D26R 	1 	1 	B01 	a: 261 mm b: 175 mm c: 220 mm
572 409 068	E43	72	680	T6/LB3 	0 	1 	B13 	a: 278 mm b: 175 mm c: 175 mm
574 012 068	E11	74	680	H6/L3 	0 	1 	B13 	a: 278 mm b: 175 mm c: 190 mm
574 013 068	E12	74	680	H6/L3 	1 	1 	B13 	a: 278 mm b: 175 mm c: 190 mm
580 406 074	F17	80	740	T7/LB4 	0 	1 	B13 	a: 315 mm b: 175 mm c: 175 mm
595 402 080	G3	95	800	H8/L5 	0 	1 	B13 	a: 353 mm b: 175 mm c: 190 mm
595 404 083	G7	95	830	D31L 	0 	1 	B01 	a: 306 mm b: 173 mm c: 225 mm
595 405 083	G8	95	830	D31R 	1 	1 	B01 	a: 306 mm b: 173 mm c: 225 mm



## ***BLACK dynamic***





În acest caz calitatea are un preț deosebit de corect. Acest lucru facilitează repararea autovehiculelor la un preț corelat cu valoarea actuală a acestuia. Din acest motiv, noua baterie **BLACK dynamic** este ideală pentru autovehicule mai vechi, mici, cu consumatori suplimentari puțini și care au deci un necesar de energie redus. Că acestea conving totuși prin tehnologia inovativă VARTA este de la sine înțeles. În fond VARTA este marca ce a fost montată și în fosta mașină nouă și satisface exigențe înalte.

- Pentru autovehicule mai mici și mai vechi***
- Facilitează efectuarea reparațiilor conform valorii actuale***
- Calitate înaltă la un preț bun***
- Putere solidă și sigură***
- Durată de funcționare mare datorită aliajului de argint eficace VARTA***

# Noua BLACK dynamic



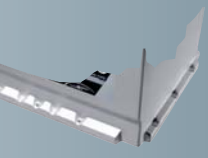

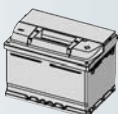
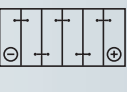
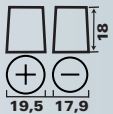
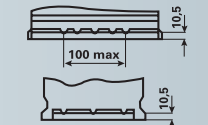
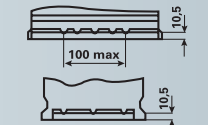
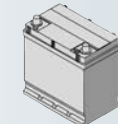
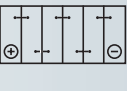
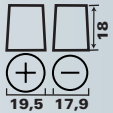
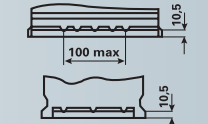
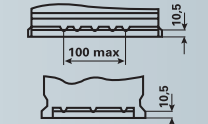
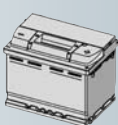
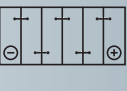
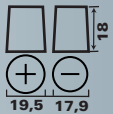
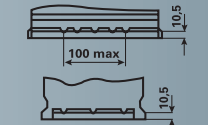
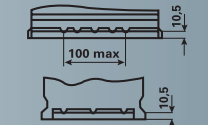







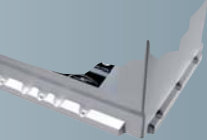



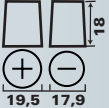
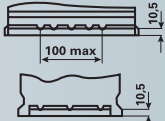

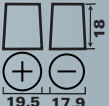
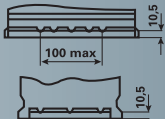
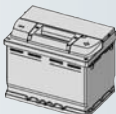

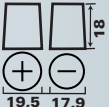
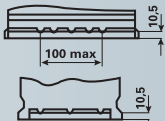
Gama de tipuri

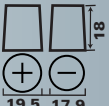
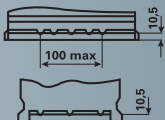

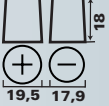
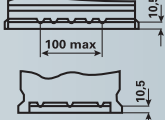
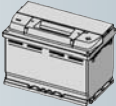
541 400 036	A17 <small>VARTA code</small>	41Ah	360 <small>energizant A-EU</small>					
541 400 036	A17	41	360	T4/LB1	0	1	B13	 a: 207 mm b: 175 mm c: 175 mm
545 077 030	B23	45	300					 a: 219 mm b: 135 mm c: 225 mm
545 079 030	B24	45	300					 a: 219 mm b: 135 mm c: 225 mm
545 412 040	B19	45	400					 a: 207 mm b: 175 mm c: 190 mm

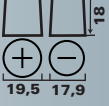
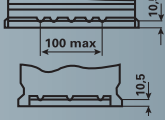
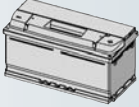
# Noua BLACK dynamic

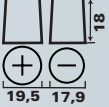
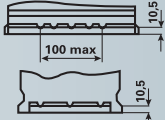
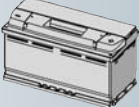
## Gama de tipuri

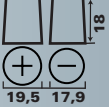
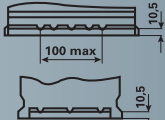
541 400 036	A17 VARTAcode	41Ah	360 minutaj motor A23V					
545 413 040	B20	45	400	H4/L1 	1 	1 	B13 	a: 207 mm b: 175 mm c: 190 mm
553 400 047	C10	53	470	T5/LB2 	0 	1 	B13 	a: 242 mm b: 175 mm c: 175 mm
556 400 048	C14	56	480	H5/L2 	0 	1 	B13 	a: 242 mm b: 175 mm c: 190 mm
556 401 048	C15	56	480	H5/L2 	1 	1 	B13 	a: 242 mm b: 175 mm c: 190 mm
570 144 064	E9	70	640	T6/LB3 	0 	1 	B13 	a: 278 mm b: 175 mm c: 175 mm
570 409 064	E13	70	640	H6/L3 	0 	1 	B13 	a: 278 mm b: 175 mm c: 190 mm
588 403 074	F5	88	740	T8/LB5 	0 	1 	B13 	a: 353 mm b: 175 mm c: 175 mm
590 122 072	F6	90	720	H8/L5 	0 	1 	B13 	a: 353 mm b: 175 mm c: 190 mm

**540 126 033**

Nr. de articol



Bornele de conexiune

**A14**

VARTA code

Notație comercială prescurtată

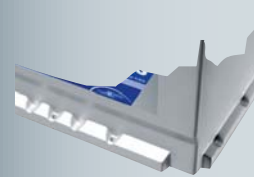

Baretele de podea

**40Ah**

Capacitatea în amperi-oră  
(20 ore la 27°C)



Lungimea

**330**

starting power A (EN)

Curentul de verificare la rece EN  
(în A la -18°C U10s/7,5V)



Lățimea



Forma constructivă



Înălțimea totală



Montajul electric

# Lista de referință pentru noul Trio dinamic

Anterior  
dynamic

SILVER  
dynamic

BLUE  
dynamic

BLACK  
dynamic

ETN	Notația prescurtată	+Adaptor Ford → +Adaptor VW →	SILVER dynamic		BLUE dynamic		BLACK dynamic	
			ETN	Notația prescurtată	ETN	Notația prescurtată	ETN	Notația prescurtată
540 128 036	B35	→			542 400 039	B35		
540 200 036	A17	→	552 401 052	C6	544 402 044	B18	541 400 036	A17
544 059 036	B19	→	554 400 053	C30	552 400 047	C22	545 412 040	B19
544 064 036	B20	→					545 413 040	B20
545 077 030	B23	→					545 077 030	B23
545 079 030	B24	→					545 079 030	B24
545 171 042	B17	→	552 401 052	C6	544 402 044	B18		
545 172 042	B18	→	552 401 052	C6	544 402 044	B18		
545 173 042	B22	→	552 401 052	C6	544 402 044	B18		
550 154 042	C22	→	554 400 053	C30	552 400 047	C22		
550 155 054 (HP)	C6	→	552 401 052	C6				
555 059 042	C14	→	563 400 061	D15	560 408 054	D24	556 400 048	C14
555 065 042	C15	→	563 401 061	D39	560 127 054	D43	556 401 048	C15
555 155 054	C10	→	561 400 060	D21	560 409 054	D59		
555 156 054	C11	→	561 400 060	D21	560 409 054	D59		
560 170 064 (HP)	D21	→	561 400 060	D21				
562 019 048	D24	→	563 400 061	D15	560 408 054	D24		
562 103 060 (HP)	D15	→	563 400 061	D15				
562 104 060 (HP)	D39	→	563 401 061	D39				
562 400 048	D43	→	563 401 061	D39	560 127 054	D43		
570 144 064	E9	→	574 402 075	E38	572 409 068	E43	570 144 064	E9
570 145 064	E10	→	574 402 075	E38	572 409 068	E43	570 144 064	E9
570 146 064	D25	→	574 402 075	E38	572 409 068	E43	570 144 064	E9
574 012 068	E11	→	577 400 078	E44	574 012 068	E11		
574 013 068	E12	→			574 013 068	E12		
575 121 072 (HP)	E38	→	574 402 075	E38				
580 122 072	F17	→	585 200 080	F18	580 406 074	F17		
585 015 076	F5	→					588 403 074	F5
585 200 080 (HP)	F18	→	585 200 080	F18				
590 122 072	F6	→	600 402 083	H3	595 402 080	G3	590 122 072	F6
590 123 072	G3	→	600 402 083	H3	595 402 080	G3	590 122 072 F6	
595 200 085 (HP)	G13	→	600 402 083	H3				
600 131 080	H3	→	600 402 083	H3				
610 200 085	I1	→	610 402 092	I1				
<b>ASIA dynamic</b>								
540 126 033	A14	→			540 126 033	A14		
540 127 033	A15	→			540 127 033	A15		
545 155 033	B31	→			545 155 033	B31		
545 156 033	B32	→			545 156 033	B32		
545 157 033	B33	→			545 157 033	B33		
545 158 033	B34	→			545 158 033	B34		
560 160 042	D45	→			570 412 063	E23		
560 161 042	D46	→			570 413 063	E24		
560 162 042	D47	→			560 410 054	D47		
560 163 042	D48	→			560 411 054	D48		
570 137 057	E23	→			570 412 054	E23		
570 138 057	E24	→			570 413 054	E24		
595 104 068	G7	→			595 404 083	G7		
595 105 068	G8	→			595 405 083	G8		

# Tipuri de adaptor

## Adaptor JIS

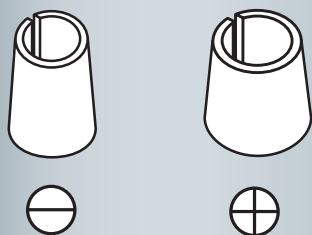

SAP 537 270

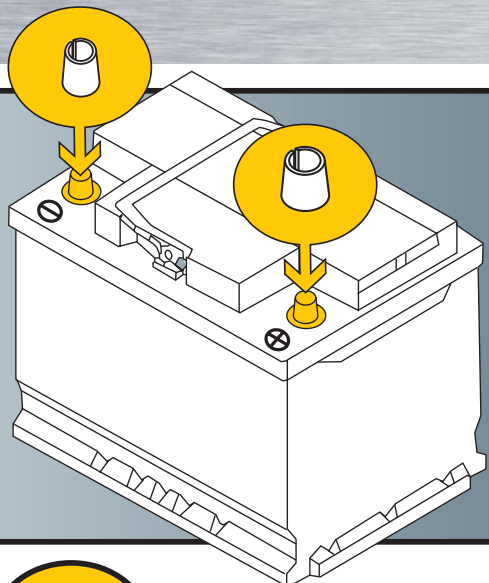

## Adaptor Ford

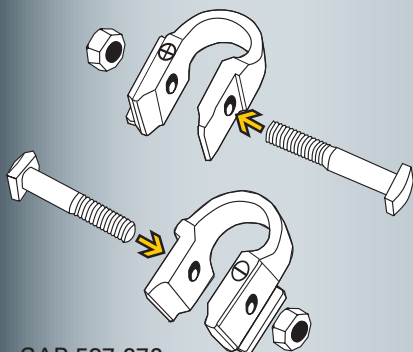

SAP 537 272

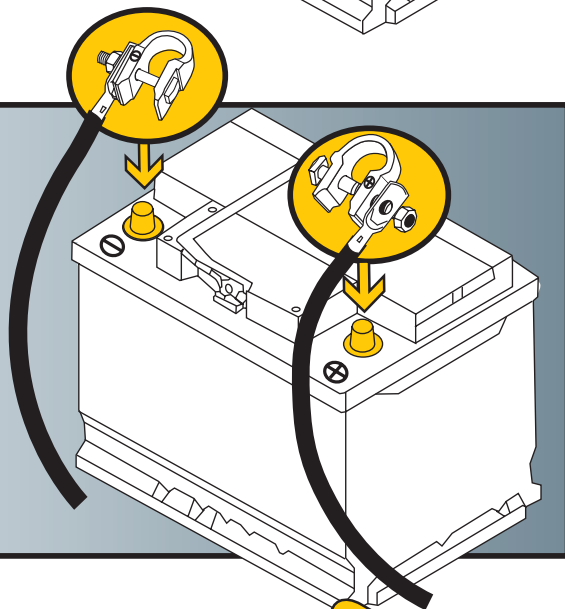

## Adaptor VW

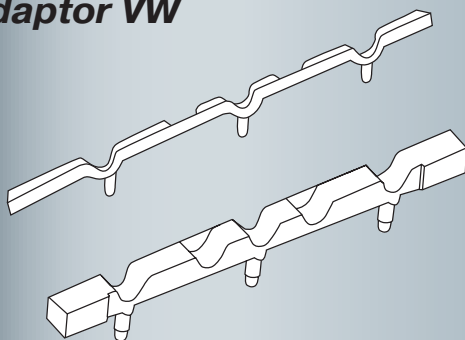

SAP 537 267

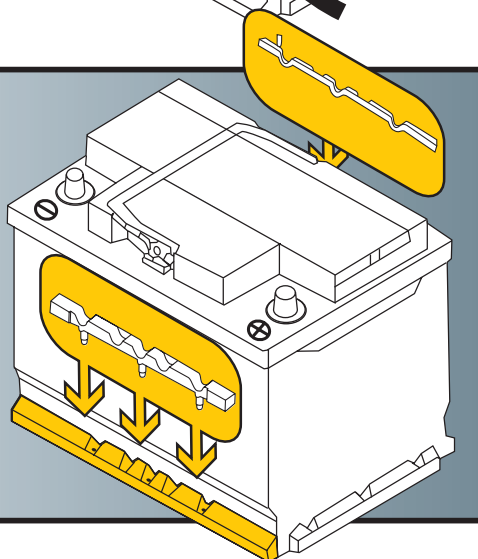

# Notes

---

---

---

---

---

---

---

---

---

---

---

---

---

---

---

---

---

---

---

---

---

---

---

---

---

---

---

---

---

---